

PREZENTARE GENERALA
Ungatoare automate



simalube[®]
smart lubrication

simalube

Avantaje pentru lubrifierea automatata folosind simalube	3
simalube – expertul in lubrifiere	4/5
simalube 15 ml	6
simalube multi-punct	7
simalube IMPULSE	8/9
Aplicatii	10/11
Ungatoare standard	12
Accesorii	13/14/15



simalube: lubrifierea continua asigura costuri reduse si fiabilitate ridicata

Milioane de unatoare simalube sunt utilizate in intreaga lume in fiecare industrie. Ele sunt cele mai bune si mai economice solutii pentru lubrifierea continua pentru perioade de pana la un an.

simalube – oriunde actioneaza forte sau ceva se roteste sau se deplaseaza.



Tom Maintain

Pentru ca rulmentii mei merita!

«Odata instalate, unatoarele simalube, ofera o lubrifiere uniforma precisa si fiabila. Acest lucru nu este posibil cu ungerea manuala.»

Avantaje de lubrifiere automata cu simalube

Ungatorul automat simalube inlocuieste lubrifierea manuala costisitoare. Acest lucru nu salveaza doar timp, de asemenea previne insuficienta sau supra-lubrifierea. Costurile pot fi astfel reduce cu pana la 30%.

Ungere optimizata

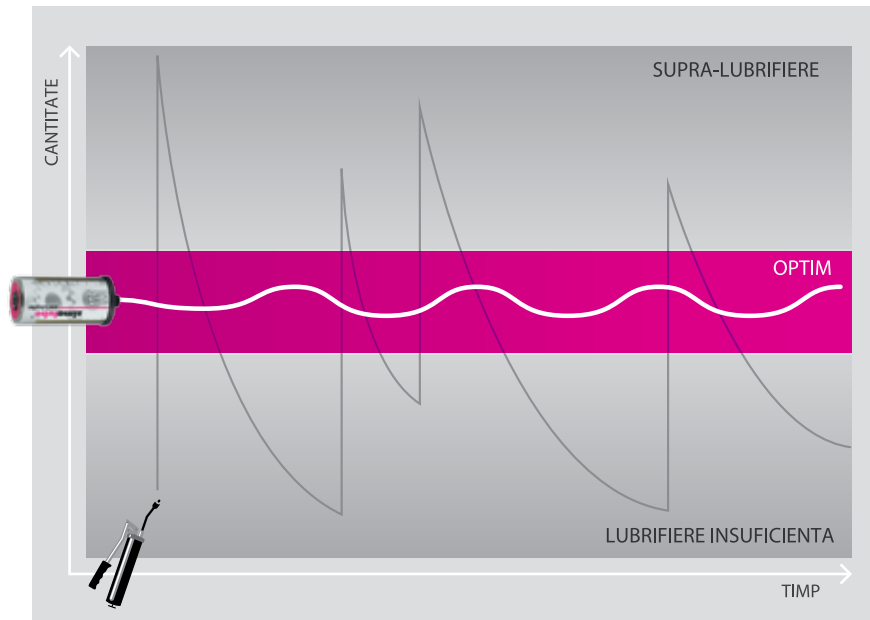

Furnizarea de lubrifiant continuu cu simalube previne in mod eficient insuficienta sau ungera in exces, care apare de multe ori la ungera manuala.

Costuri mai reduce datorita simalube



Costuri mai mici cu pana la 30%:

- Timp economisit si o mai mare siguranta in munca datorita intervalelor de intretinere mai putine
- Creste timpul de viata al masinii si mai putine opriri neprogramate

Beneficiile lubrifierii automate cu simalube



Fara lubrifiere manuala

- Timp economisit
- O mai mare securitate a muncii
- Punctele de lubrifiere greu accesibile sunt unse permanent
- Reduce consumul de lubrifiant

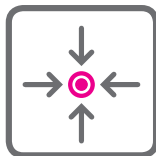

Fara insuficienta sau supra-lubrifiere a componentelor

- Uzura reducea
- Timpul scazut de nefunctionare a masinii
- Creste performanta masinii

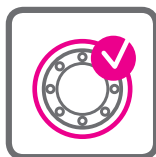

Sigilat, sistem rezistent la praf si apa

- Fara confuzie de lubrifianti
- Reducerea riscului de contaminare
- Nu se contamineaza punctele de ungera



Conformitate cu standardele internationale

- Testat – TUV si Certificat Ex in toate zonele
- Imbunatatirea sigurantei la locul de munca
- Fara impact asupra mediului, ungetoarele Simalube pot fi reciclate

simalube –
expertul in lubrifiere



simalube – ungator automat intr-un singur punct

Disponibil in 5 dimensiuni, simalube furnizeaza in diferite puncte de ungere lubrifiant non-stop.
Zi de zi intr-o perioada de pana la un an.

Profita de avantajele simalube

Fiabilitate

- Punctele de lubrifiere sunt alimentate continuu cu lubrifiant
- Nici un punct de lubrifiere nu este omis
- Monitorizare usoara a procesului de dozare datorita carcasei transparente

Salvarea mediului

- Ungatoarele simalube pot fi reumplute de pana la 3 ori
- Inlocuire usoara dupa golirea ungatorului
- Ungatoarele simalube nu contin substante toxice

Flexibilitate

- simalube este disponibil in 5 dimensiuni: 15, 30, 60, 125 si 250 ml
- Ciclul de distributie la libera alegere de la 1 pana la 12 luni
- Ciclul de distributie poate fi modificat oricand
- simalube este disponibil plin cu vaselina sau gol pentru auto-umplere

Utilizari nelimitate in diferite aplicatii (a se vedea paginile 10/11)

- In spatii inchise si greu accesibile
- In orice locatie, chiar si sub apa
- La temperaturi ambientale de -20 °C pana la +55 °C
- Numeroase optiuni de instalare, datorita unei game largi de accesorii
- Gama standard de ungatoare include lubrifianti de inalta performanta de ultima generatie si certificati in toate aplicatiile (vezi paginile 12/13)

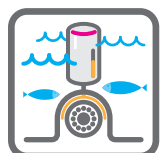
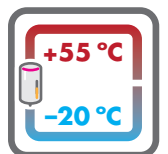
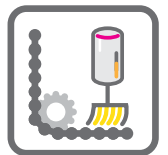

**TOM's
TIP**

Mai multe informatii tehnice si manualul de utilizare pot fi
descarcate de pe www.simatec.com/en/simalube



Componente

Generator de gaz

Camera de presiune

Carcasa

Piston

Eticheta

Lubrifiant

Conexiune

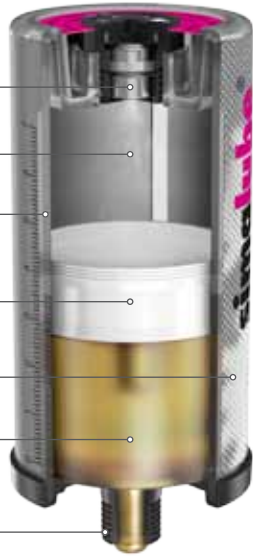

Specificatii

Produs	Ungator automat pe termen lung pentru vaselina si ulei			
Generare putere	Pastila/cartus uscat ce produce gaz de hidrogen			
Presiune de lucru	Max. 5 bari			
Ajustare	Trepte 1-12 luni (in conditii standard)			
Temperatura de operare	-20 °C la +55 °C temperatura ambientala (Consistenta vaselinei se schimba cu temperatura)			
Temperatura de depozitare	Recomandat la 20 °C ±5 °C			
Volum ungtor	30 ml	60 ml	125 ml	250 ml
Greutate plin	~82 g	~115 g	~190 g	~335 g
Greutate gol	~55 g	~60 g	~75 g	~111 g
Reumplere	Ungatoarele simalube 30-250 ml sunt reincarcabile.			



Certificari



simalube 250



simalube 125



simalube 60



simalube 30



Pentru a determina setarea dimensiunii si a timpului, utilizati programul nostru gratuit «Calculation Pro» de pe www.simatec.com/en/calpro



simalube 15 ml



Cel mai mic ungator automat

In spati inchise, la cei 15 ml simalube ofera solutia perfecta. Cu dimensiunile sale compacte, este unic pe piata mondiala ca fiind cel mai mic ungator automat. Acesta functioneaza la fel ca ungatoarele simalube mai mari si ofera aceleasi avantaje.

De dimensiuni mici ofera o performanta mare

- Economie de spatiu, datorita dimensiunii compacte
- Carcasa robusta din aluminiu
- Aceeasi instalare, functioneaza ca restul ungatoarelor automate simalube
- Alternativa simalube Multi-punct atunci cand sunt necesare mai mult de 5 puncte de ungere (a se vedea pagina 7)

Dimensiuni



Specificatii

Produs	Ungator automat pe termen lung pentru vaselina si ulei
Generare putere	Pastila/cartus uscat ce produce gaz de hidrogen
Presiune de lucru	Max. 5 bari
Ajustare	Trepte 1-12 luni (in conditii standard)
Temperatura de operare	-20 °C la +55 °C temperatura ambientala (Consistenta vaselinei se schimba cu temperatura)
Temperatura de depozitare	Recomandat la 20 °C ±5 °C
Volum ungator	15 ml
Greutate plin/gol	~35 g / ~21,5 g
Certificari	CE IP 68

simalube multipoint



Ungator automat multi-punct

simalube multi-punct furnizeaza simultan 5 puncte de lubrifiere pe o perioada de timp de pana la un an, in acelasi mod fiabil ca si ungaroarele simalube intr-un singur punct. Datorita conexiunii rapide simalube multi-punct poate fi inlocuit cu usurinta si rapid cand este gol.



Ungator adaptat pentru ghidaje liniare

- 5×8 ml volum ungtor
- Permite furnizarea foarte scazuta de lubrifiant pe o perioada lunga de timp
- Conexiune rapida pentru multi-punct
- Cuplaje rapide pentru conectarea furtunurilor
- Ideal pentru lubrifierea ghidajelor liniare

Dimensiuni



Specificatii

Produs	Ungator automat multi-punct pe termen lung pentru vaselina si ulei
Generare putere	Pastila/cartus uscat ce produce gaz de hidrogen
Presiune de lucru	Max. 5 bari
Ajustare	Trepte 1-12 luni (in conditii standard)
Temperatura de operare	-20 °C la +55 °C temperatura ambientala (Consistenta vaselinei se schimba cu temperatura)
Temperatura de depozitare	Recomandat la 20 °C ± 5 °C
Volum ungtor	5×8 ml
Greutate plin/gol	~147 g / ~120 g
Certificari	  

simalube IMPULSE



Amplificator de presiune de pana la 10 bari

Amplificatorul simalube asigura o lubrifiere sigura si controlata in situatii cu presiune ridicata si linii de lubrifiere lungi. Cu ungatoarele automate simalube acest amplificator de presiune distribuie vaselina si uleiuri cu o presiune de pana la 10 bari si 0,5 ml per impuls, pana la punctul de lubrifiere vizat.

Afisaj LED, amplificatorul de presiune inteligent ofera informatii continuu despre starea actuala de functionare. LED-urile clipesc verde atunci cand dispozitivul functioneaza corect.

Dispozitiv de putere intr-o forma compacta

Funcionalitate

- Impulsuri de lubrifiere a 0,5 ml de ulei sau vaselina de pana la NLGI 2 la o presiune de pana la 10 bari
- Indicarea starii de functionare cu ajutorul afisajului LED (verde / rosu)
- Timpul de distributie poate fi modificat in orice moment prin intermediul ungatorului
- Sistem modular perfect compatibil cu ungatoarele simalube de 60, 125 si 250 ml
- Ungatorul simalube poate fi inlocuit fara a indeparta amplificatorul
- Potrivit pentru toti lubrifiantii, deoarece numai cantitatea dozata este sub presiune

Diverse aplicatii

- Poate fi instalat in afara zonelor cu temperatura inalta sau periculoase cu tuburi de pana la 4 metri lungine
- Format compact, poate fi instalat in spatii foarte mici
- Functioneaza perfect in toate pozitiile, chiar si sub apa

Eficienta

- Salveaza costurile ridicate datorita posibilitatii de reutilizare



**TOM's
TIP**



Mai multe informatii tehnice si un videoclip pentru simalube IMPULSE gasiti la www.simatec.com/en/impulse

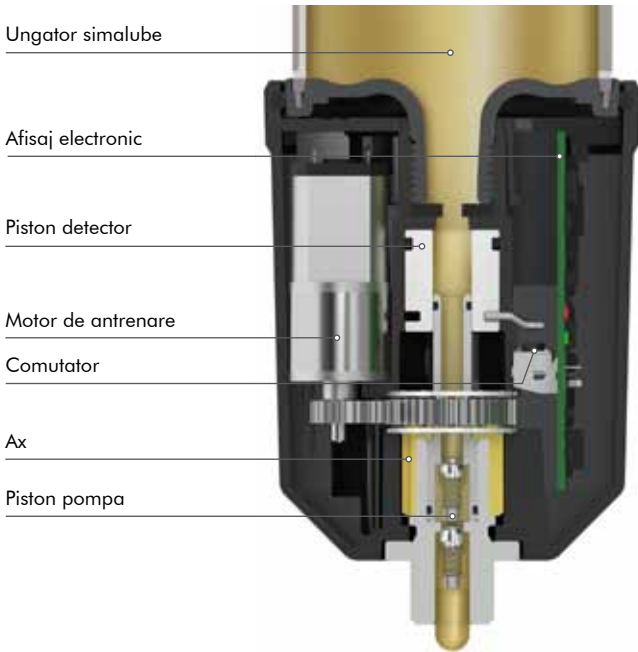

Componente



Specificatii

Produs	Amplificator de presiune automat pentru unghatoare simalube
Sistem de actionare	Electromecanic
Alimentare electrica	Acumulator, 6 V 2,3 Ah Acumulator pentru temperaturi scazute, 6 V 2,9 Ah
Afisaj functionare	Statusul de afisare cu LED-uri: verde / rosu la fiecare 10 secunde
Volum de distributie	0,5 ml per cursa
Presiunea de lucru	Pana la 10 bari
Setarea timpului	1 pana la 12 luni – determinat de setarea unghatorului simalube
Temperatura de operare	-10 °C pana la +55 °C
Doza de lubrifiere	In functie de marime si setarile unghatorului simalube: 0,17 pana la 8,3 ml/zi
Volum unghator	Conform unghatoarelor: 60 ml, 125 ml sau 250 ml
Lubrifiant	Vaselina pana la NLGI 2 sau ulei
Pozitia de instalare	Oricare
Greutate	0,24 kg
Garantia si durata de viata	3 ani de la data de productie sau pana cand 10 unghatoare simalube (125 ml) s-au golit
Certificari/Testari	 



Instalati simalube IMPULSE



Instalati simalube IMPULSE.
Se introduce acumulatorul,
insurubati unghatorul Simalube si
reglati timpul.

Simpla reincarcare



Procura acumulator nou si un
nou cartus, reumpleti unghatorul
singuri ...



... sau achizitioneaza un nou
pachet de acumulatori si un
nou unghator simalube.



Aplicatii simalube

DISPOZITIVE DE RIDICARE



Axele de la o statie de ridicare pentru vagoane de cale ferata si locomotive sunt lubrifiate cu ungtor simalube 125 ml setat pentru 12 luni.

INDUSTRIA ALIMENTARA



Lantul de antrenare al unei benzi de transport, ceea ce permite roletelor sa se raceasca, se curata cu perii albastre speciale si este uns cu 2 ungtoare simalube SL 18 cu dimensiuni de 30 si 60 ml.

STATII DE PIETRIS SI BETON



Doua ungtoare simalube 250 ml cu perii , asigura ungerea si curatarea lantului de antrenare de la o masina de spalare cu tambur.

MACARALE



Ungtor simalube 125 ml, asigura ungerea ansamblului de rotatie a unei macarale.

STATIE DE PIETRIS SI BETON



Amplificatorul simalube impreuna cu un ungator simalube 125 ml este folosit in balastiere. Amplificatorul impinge lubrifiantul cu o presiune de 10 bari printr-o linie de lubrifiere de 4 metri.

ASCENSOARE SI SCARI RULANTE



simalube 125 ml mentine ghidarea sinei ascensoarelor si previne frecarea uscata. Sistemul este atasat direct pe acoperisul cabinei.

INDUSTRIA TIPOGRAFICA



Un ungator simalube multi-punct poate lubrifia 5 ghidaje liniare ale unei masini de taiat si stivuit hartie dintr-o tipografie.

STATII DE EPURARE SI ALIMENTARE CU APA



Ungatorul de 60 ml montat pe motorul electric al arborelui de antrenare asigura o lubrifiere continua a unei pompe centrifuge.

RECICLARE



Un ungator 125 ml lubrifiaza lagarul pedestal al unei benzi transportoare.

FABRICA DE PRODUCTIE



Ungatoare simalube de 15 ml cu perii ce asigura ungerea cu ulei a cremalierii unei masini de incarcata. Un alt ungator simalube de 15 ml asigura ungerea cu vaselina a rulmentilor.



**TOM's
TIP**

Multe alte aplicatii pot fi gasite pe www.simatec.com/en/simalube-applications





Tipuri de vaselina standard si accesorii

VASELINA	NLGI	Agent de ingrosare	Interval de temperatura	Vascozitate la 40 °C	Aplicatii						
					Rulmenti cu role	Lagare de alunecare	Ghidaje liniare	Angrenaje/ Roli citrate	Surub conductor	Arbore de antrenare	Lanturi
SL01 Rezistenta la apa, vaselina pe termen lung	2	Litiu-calcium	-30 °C pana la 120 °C	118	+	+	•	•	+	+	-
SL02 Vaselina de inalta performanta cu MoS ₂	2	Litiu	-25 °C pana la 130 °C	270	•	+	-	+	-	-	-
SL04 Vaselina pentru temperatura ridicata pentru lubrifiere pe termen lung (EP)	2	Anorganic agent de ingrosare	-20 °C pana la 160 °C	540	+	•	-	•	•	-	-
SL06 Rezistenta la apa, vaselina fluida (EP)	0	Litiu-calcium	-20 °C pana la 120 °C	150	+	+	+	+	•	-	-
SL09 Vaselina universala, usor biodegradabila	2	Litiu-calcium	-20 °C pana la 100 °C	100	+	+	•	•	-	-	-
SL10 Vaselina speciala pentru industria alimentara, a bauturilor si industria farmaceutica	2	Complex de aluminiu	-30 °C pana la 140 °C	350	+	+	•	+	•	-	-
SL24 Vaselina pentru o gama larga de temperaturi (EP)	2	Complex de litiu	-30 °C pana la 140 °C	185	+	+	•	•	+	+	-
SL25 Vaselina poliuree pentru temperaturi ridicate	2	Poliuree	-20 °C pana la 160 °C	110	+	•	-	•	•	-	-
SL26 Vaselina complexa sulfonate de calciu (EP)	1,5	Complex de calciu	-20 °C pana la 150 °C	460	+	+	-	•	•	-	-

+ recomandat • posibil - nu se recomanda



**TOM's
TIP**

Specificatii tehnice sunt disponibile pentru toate tipurile de vaselina si ulei pe www.simatec.com/en/lubricants



ULEI	ISO-VG	Ulei de baza	Interval de temperatura	Vascozitate la 40 °C	Aplicatii						
					Rulmenti cu role	Lagare de alunecare	Ghidaje liniare	Angrenaje/Rei dintate	Surub conductor	Arbore de antrenare	Lanturi
SL14 Ulei de lant (EP)	68	Ulei mineral	-10 °C pana la 90 °C	68	-	•	•	-	-	-	+
SL15 Ulei de lant de temperatura ridicata (EP)	-	Ulei sintetic	-30 °C pana la 250 °C	250	-	•	•	-	-	-	+
SL16 Ulei lubrifiere parafina	68	Ulei mineral	-20 °C pana la 100 °C	68	-	•	•	-	-	-	+
SL18 Ulei ungere de inalta performanta industri- ria produselor alimentare, industria hranei pentru animale si industria farmaceutica	220	Ulei sintetic	-15 °C pana la 150 °C	220	-	•	•	-	-	-	+
SL19 Ulei organic pentru lant	-	Ulei de rapita	-15 °C pana la 100 °C	60	-	•	•	-	-	-	+

+ recomandat • posibil - nu se recomanda

Exemple de aplicatii

Ungatoarele simalube pot fi instalate cu usurinta oriunde si in orice pozitie cu aceste accesorii.

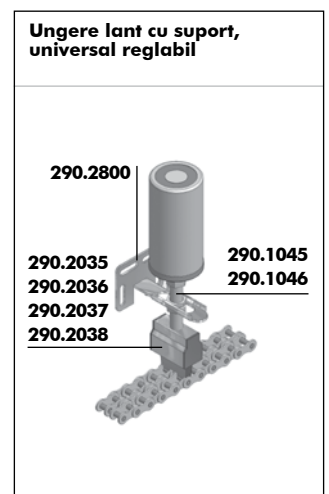
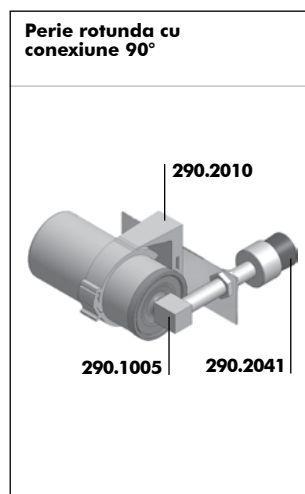
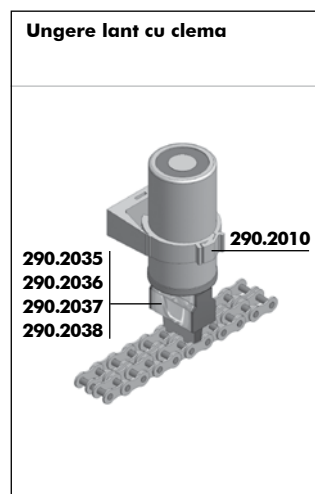
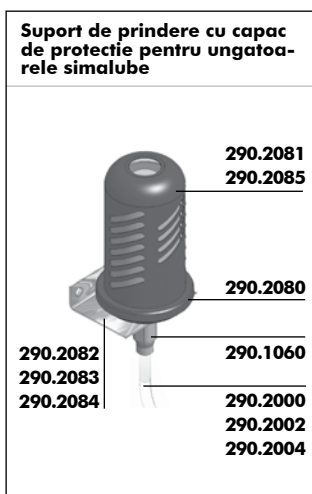
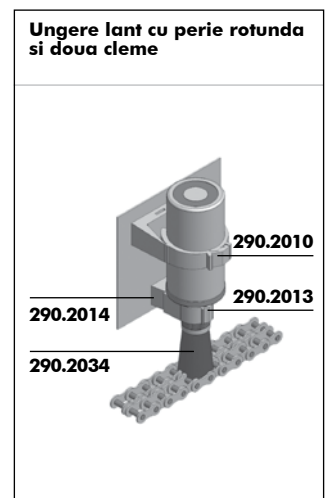
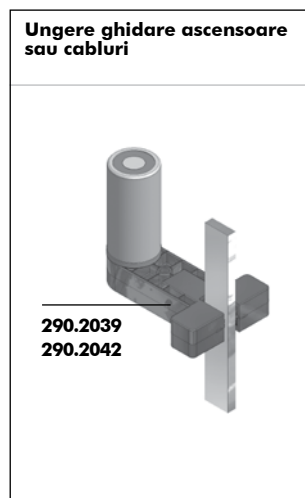
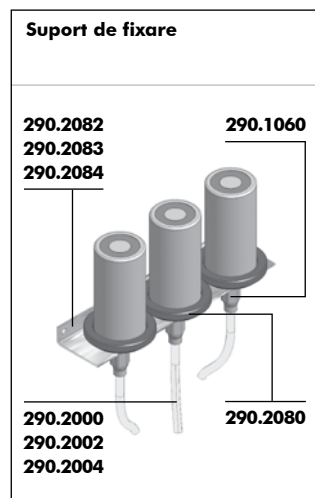
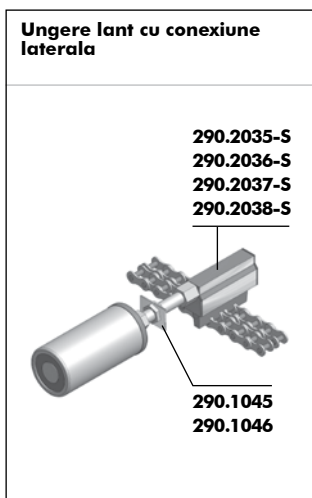

Conexiuni

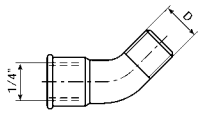
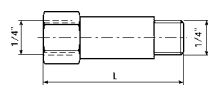
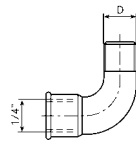
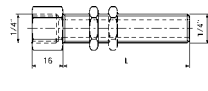
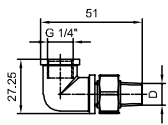
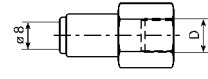
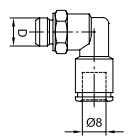
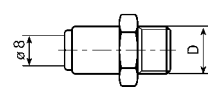
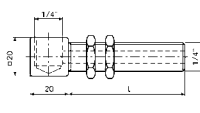
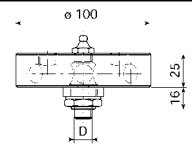
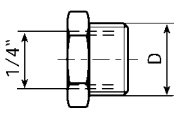
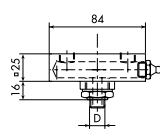
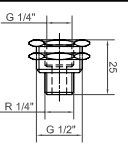
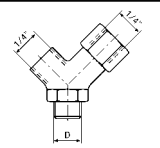
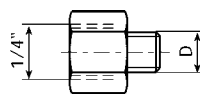
	Racord cot la 45° D R 1/4 Nr. 290.1001		Extensie L 10 35 50 [mm] Nr. 290.1021 290.1040 290.1041
	Racord cot la 90° D R 1/4 Nr. 290.1002		Conexiune cu fileț, cu gaura, 25 mm incl. 1 piulita / 60 mm incl. 2 piulite L 25 60 [mm] Nr. 290.1045 290.1046
	Racord cot la 90° pivotanta D R 1/4 Nr. 290.1004		Conexiune rapida, pentru furtun Ø 8 mm D G 1/4 Nr. 290.1060
	Cot rotativ, pentru furtun Ø 8 mm D G 1/8 G 1/4 Nr. 290.1007 290.1008		Conexiune rapida, pentru furtun Ø 8 mm D G 1/8 G 1/4 G 3/8 Nr. 290.1070 290.1071 290.1072
	Racord la 90° cu fileț, incl. 2 piulite (numai pentru ulei) L 70 [mm] Nr. 290.1005		Adaptor 4 iesiri D G 1/2 G 1/4 Nr. 290.4100 290.4101
	Niplu conectare D G 3/8 G 1/2 Nr. 290.1010 290.1011		Adaptor 2 iesiri D G 1/2 G 1/4 Nr. 290.4102 290.4103
	Niplu fixare G 1/2" - R 1/4" L 25 [mm] Nr. 290.1015		Conexiune Y, contine reductie art. 290.1021 D R 1/4 Nr. 290.1050
	Niplu reductie D G 1/8 G 1/4 M 6 M 8 M 8x1 Nr. 290.1020 290.1021 290.1022 290.1023 290.1024 D M 10 M 10x1 M 12 M 12x1.5 UNF 1/4 Nr. 290.1025 290.1026 290.1027 290.1028 290.1121		

Diverse accesorii de lubrifiere

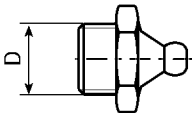
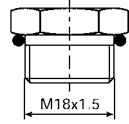
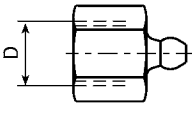
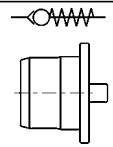
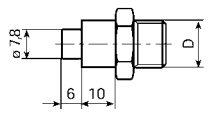
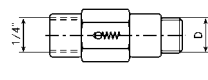
	Niplu umplere, pentru curatarea si umplerea liniilor de ungere D R 1/4 Nr. 290.3011		Generator de gaz, pentru reumplere Nr. 30 ml 60 ml 125 ml 250 ml 220.5004 220.5006 220.5008 220.5010
	Niplu reumplere, pentru reumplerea de unatoare simalube D G 1/4 Nr. 290.3012		Capac supapa de retinere, din plastic Nr. 290.5060
	Niplu reumplere, la pistol de gresare pentru reumplerea de unatoare simalube D R 1/4 R 3/8 Nr. 290.3013 290.3014		Supapa de retinere D G 1/8 G 1/4 Nr. 290.2020 290.2021

Accesorii de siguranta

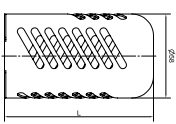
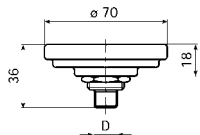
	Capac de protectie, pentru suport de montare art. 290.2080 L ≤125 ml 250 ml 105 195 [mm] Nr. 290.2081 290.2085		Suport de montare, pentru toate dimensiunile de unatoare simalube D R 1/4 Nr. 290.2080
---	---	--	--

Perii

	<p>Perie rotunda</p> <p>D x L Ø 25 x 45 [mm] Nr. 290.2034</p>		<p>Perie conexiune laterala, SFN pentru aplicatii in industria alimentara</p> <table border="1"> <tr> <td>L</td> <td>25</td> <td>40</td> <td>70</td> <td>100</td> <td>[mm]</td> </tr> <tr> <td>Nr.</td> <td>290.2038-S</td> <td>290.2035-S</td> <td>290.2036-S</td> <td>290.2037-S</td> <td></td> </tr> <tr> <td>Nr.</td> <td>290.2038-SFN</td> <td>290.2035-SFN</td> <td>290.2036-SFN</td> <td>290.2037-SFN</td> <td></td> </tr> </table>	L	25	40	70	100	[mm]	Nr.	290.2038-S	290.2035-S	290.2036-S	290.2037-S		Nr.	290.2038-SFN	290.2035-SFN	290.2036-SFN	290.2037-SFN			
L	25	40	70	100	[mm]																		
Nr.	290.2038-S	290.2035-S	290.2036-S	290.2037-S																			
Nr.	290.2038-SFN	290.2035-SFN	290.2036-SFN	290.2037-SFN																			
	<p>Perie rotunda scurta</p> <p>D x L Ø 25 x 15 [mm] Nr. 290.2041</p>		<p>Perie pentru ascensor, 5-16 mm, inaltime 32 mm</p> <p>Perie pentru ascensor, 16-32 mm, inaltime 32 mm</p> <table border="1"> <tr> <td>Nr.</td> <td>290.2039</td> <td>Nr.</td> <td>290.2044</td> </tr> </table>	Nr.	290.2039	Nr.	290.2044																
Nr.	290.2039	Nr.	290.2044																				
	<p>Perie, FN pentru aplicatii in industria alimentara</p> <table border="1"> <tr> <td>L</td> <td>25</td> <td>40</td> <td>70</td> <td>100</td> <td>[mm]</td> </tr> <tr> <td>Nr.</td> <td>290.2038</td> <td>290.2035</td> <td>290.2036</td> <td>290.2037</td> <td></td> </tr> <tr> <td>Nr.</td> <td>290.2038-FN</td> <td>290.2035-FN</td> <td>290.2036-FN</td> <td>290.2037-FN</td> <td></td> </tr> </table>	L	25	40	70	100	[mm]	Nr.	290.2038	290.2035	290.2036	290.2037		Nr.	290.2038-FN	290.2035-FN	290.2036-FN	290.2037-FN			<p>Perie mica pentru ascensor, 5-16 mm, inaltime 32 mm</p> <table border="1"> <tr> <td>Nr.</td> <td>290.2042</td> </tr> </table>	Nr.	290.2042
L	25	40	70	100	[mm]																		
Nr.	290.2038	290.2035	290.2036	290.2037																			
Nr.	290.2038-FN	290.2035-FN	290.2036-FN	290.2037-FN																			
Nr.	290.2042																						

Accesorii de instalare

	<p>Furtun, disponibil la metru</p> <p>L per metru Ø 8/6 mm Nr. 290.2000/...m</p>		<p>Adaptor pentru cleme (60 mm), din plastic</p> <table border="1"> <tr> <td>D</td> <td>50</td> <td>[mm]</td> </tr> <tr> <td>Nr.</td> <td>290.2012</td> <td></td> </tr> </table>	D	50	[mm]	Nr.	290.2012										
D	50	[mm]																
Nr.	290.2012																	
	<p>Furtun pentru temperaturi de pana la 260 °C, disponibil la metru</p> <p>L per metru Ø 8/6 mm Nr. 290.2002/...m</p>		<p>Distanțier clema, pentru fixare perie rotunda art. 290.2013</p> <table border="1"> <tr> <td>H</td> <td>15</td> <td>[mm]</td> </tr> <tr> <td>Nr.</td> <td>290.2014</td> <td></td> </tr> </table>	H	15	[mm]	Nr.	290.2014										
H	15	[mm]																
Nr.	290.2014																	
	<p>Furtun cu raza de indoire mica, disponibil la metru</p> <p>L per metru Ø 8/6 mm Nr. 290.2004/...m</p>		<p>Suport, pentru montaj simalube art. 290.2080</p> <table border="1"> <tr> <td></td> <td>1x</td> <td>3x</td> <td>5x</td> <td></td> </tr> <tr> <td>L</td> <td>75</td> <td>240</td> <td>390</td> <td>[mm]</td> </tr> <tr> <td>Nr.</td> <td>290.2082</td> <td>290.2083</td> <td>290.2084</td> <td></td> </tr> </table>		1x	3x	5x		L	75	240	390	[mm]	Nr.	290.2082	290.2083	290.2084	
	1x	3x	5x															
L	75	240	390	[mm]														
Nr.	290.2082	290.2083	290.2084															
	<p>Clema pentru unghitoare/perii rotunde, din plastic</p> <table border="1"> <tr> <td>D</td> <td>22</td> <td>28</td> <td>50</td> <td>[mm]</td> </tr> <tr> <td>Nr.</td> <td>290.2015</td> <td>290.2013</td> <td>290.2010</td> <td></td> </tr> </table>	D	22	28	50	[mm]	Nr.	290.2015	290.2013	290.2010			<p>Suport, universal reglabil</p> <table border="1"> <tr> <td>Nr.</td> <td>290.2800</td> </tr> </table>	Nr.	290.2800			
D	22	28	50	[mm]														
Nr.	290.2015	290.2013	290.2010															
Nr.	290.2800																	
	<p>Suport magnetic, pentru cleme</p> <table border="1"> <tr> <td>Nr.</td> <td>290.2019</td> </tr> </table>	Nr.	290.2019															
Nr.	290.2019																	

Componente de instalare simalube multi-punct

	<p>Conectare rapida, pentru furtun Ø 4 mm</p> <table border="1"> <tr> <td>D</td> <td>R 1/8</td> <td>R 1/4</td> <td>M 5</td> <td>M 6</td> </tr> <tr> <td>Nr.</td> <td>290.1170</td> <td>290.1171</td> <td>290.1172</td> <td>290.1173</td> </tr> </table>	D	R 1/8	R 1/4	M 5	M 6	Nr.	290.1170	290.1171	290.1172	290.1173		<p>Furtun, disponibil la metru</p> <table border="1"> <tr> <td>L</td> <td>per metru</td> <td>Ø 4/2,7 mm</td> </tr> <tr> <td>Nr.</td> <td>290.2100/...m</td> <td></td> </tr> </table>	L	per metru	Ø 4/2,7 mm	Nr.	290.2100/...m	
D	R 1/8	R 1/4	M 5	M 6															
Nr.	290.1170	290.1171	290.1172	290.1173															
L	per metru	Ø 4/2,7 mm																	
Nr.	290.2100/...m																		
	<p>Conexiune SLM</p> <table border="1"> <tr> <td>D</td> <td>5 x Ø 4 mm</td> </tr> <tr> <td>Nr.</td> <td>290.2900</td> </tr> </table>	D	5 x Ø 4 mm	Nr.	290.2900														
D	5 x Ø 4 mm																		
Nr.	290.2900																		

Cartus de vaselina si bidon de ulei pentru preungere

	<p>Cartus vaselina, 400 ml</p> <table border="1"> <tr> <td></td> <td>SL01</td> <td>SL02</td> <td>SL04</td> <td>SL06</td> <td>SL09</td> </tr> <tr> <td>Nr.</td> <td>290.7001</td> <td>290.7002</td> <td>290.7004</td> <td>290.7006</td> <td>290.7009</td> </tr> <tr> <td></td> <td>SL10</td> <td>SL24</td> <td>SL25</td> <td>SL26</td> <td></td> </tr> <tr> <td>Nr.</td> <td>290.7010</td> <td>290.7024</td> <td>290.7025</td> <td>290.7026</td> <td></td> </tr> </table>		SL01	SL02	SL04	SL06	SL09	Nr.	290.7001	290.7002	290.7004	290.7006	290.7009		SL10	SL24	SL25	SL26		Nr.	290.7010	290.7024	290.7025	290.7026			<p>Bidon ulei, 0,5 l</p> <table border="1"> <tr> <td></td> <td>SL14</td> <td>SL15</td> <td>SL16</td> <td>SL18</td> <td>SL19</td> </tr> <tr> <td>Nr.</td> <td>290.7114</td> <td>290.7115</td> <td>290.7116</td> <td>290.7118</td> <td>290.7119</td> </tr> </table>		SL14	SL15	SL16	SL18	SL19	Nr.	290.7114	290.7115	290.7116	290.7118	290.7119
	SL01	SL02	SL04	SL06	SL09																																		
Nr.	290.7001	290.7002	290.7004	290.7006	290.7009																																		
	SL10	SL24	SL25	SL26																																			
Nr.	290.7010	290.7024	290.7025	290.7026																																			
	SL14	SL15	SL16	SL18	SL19																																		
Nr.	290.7114	290.7115	290.7116	290.7118	290.7119																																		

Accesorii simalube IMPULSE

	<p>simalube IMPULSE, amplificator de presiune</p> <table border="1"> <tr> <td>Nr.</td> <td>230.1000</td> </tr> </table>	Nr.	230.1000		<p>Acumulator</p> <table border="1"> <tr> <td>Putere</td> <td>6 V 2,3 Ah</td> <td>6 V 2,9 Ah</td> </tr> <tr> <td>Nr.</td> <td>230.5000</td> <td>230.5001</td> </tr> </table>	Putere	6 V 2,3 Ah	6 V 2,9 Ah	Nr.	230.5000	230.5001
Nr.	230.1000										
Putere	6 V 2,3 Ah	6 V 2,9 Ah									
Nr.	230.5000	230.5001									

Distribuitor Autorizat România:

POLYGONScule și echipamente industriale
www.polygon.ro**POLYGON TRADING S.R.L.**

BUCUREȘTI

Șos. Odăi nr. 27, Sector 1,
RO-013601

Tel.: 021-351.68.00 / 01 / 02

Fax: 021-351.88.03

E-mail: office@polygon.ro

CLUJ-NAPOCA

Str. Fluturilor nr. 8,
RO-400440

Tel.: 0264-431.479

Tel./Fax: 0264-594.232

E-mail: bogdan@polygon.ro

simalube
Video

simatec – Soluții inovatoare care oferă beneficii remarcabile pentru clienți

simatec este o companie elvețiană de familie care operează pe plan internațional. De la înființare, din anul 1983, angajații noștri motivați au dezvoltat și creat produse inovative pentru întreținerea rulmenților sub branșurile simalube, simatherm, și simatool.

Noi cei de la simatec punem accentul pe furnizarea de beneficii directe clienților: Noile tehnologii ne permit simplificarea operațiilor complexe și reducerea nivelului de întreținere necesar pe mii de mașini din întreaga lume.

Distribuitorii noștri selectați vând produse, simatec pentru întreținerea la nivel mondial, precum și servicii profesionale și consultanță.

Produse de întreținere simatec – Tehnologie industrială



Ungatoare

Ungatoarele simalube asigură ungerea automată pe o perioadă între o lună și un an și poate fi ajustată conform cerințelor aplicațiilor. simalube livrează la fiecare punct de ungere cantitatea optimă de lubrifiant – ulei sau vaselină – ungerea manuală ne mai fiind necesară, iar costurile de mentenanță se reduc semnificativ.



Aparate de încălzit prin inducție

Aparatele de încălzit prin inducție simatherm încălzesc piese metalice circulare, cum ar fi rulmenți, într-un timp foarte scurt astfel încât să poată fi instalați rapid și eficient. Încălzirea prin inducție a pieselor metalice are sens atât din punct de vedere economic cât și din perspectiva ecologică. simatec este lider mondial pentru producerea aparatelor de încălzit prin inducție.



Truse scule pentru rulmenți

Seturile simatool permit montarea și demontarea rapidă a rulmenților și a semerinelor. Sunt folosite peste tot în lume, în departamentele de întreținere din toate industriile.

simalube[®]
smart lubrication**simatherm**[®]
smart mounting**simatool**[®]
smart tools